

INNOVATION MADE IN GERMANY

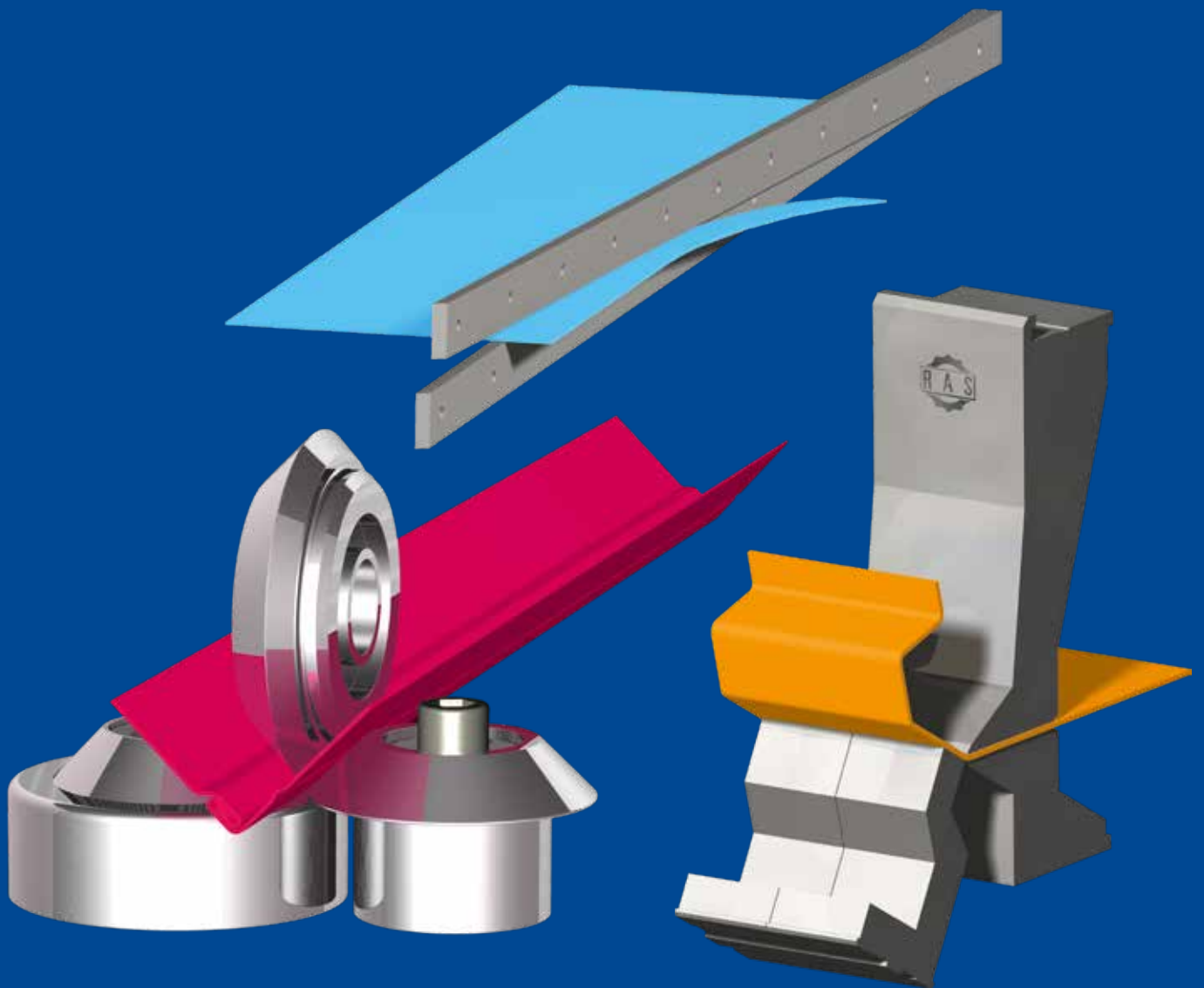

Production Program



CUTTING

BENDING

FORMING

SOFTWARE

Swing Beam Shears

POWERcut

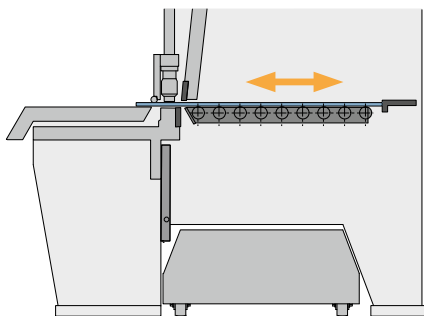

The sorting and sheet support system holds the blank flat before the cut. This eliminates the material from hanging down and guarantees for perfect cutting dimensions.

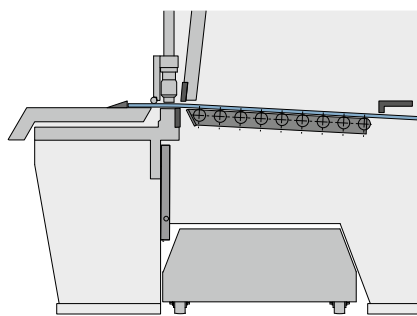

Extra long sheets can be cut while passing underneath the backgauge. The backgauge moves to its maximum dimension and the sheet support moves slightly downward.

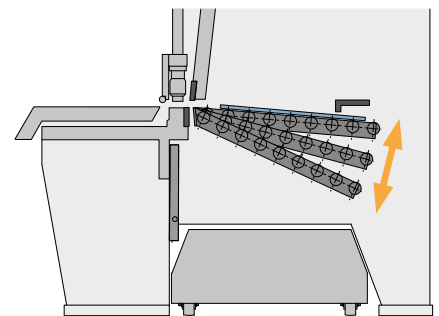

After the cut is made, the sheet support system can tilt to three different angles. Even small strips of 40 mm can slide down quietly and gently.

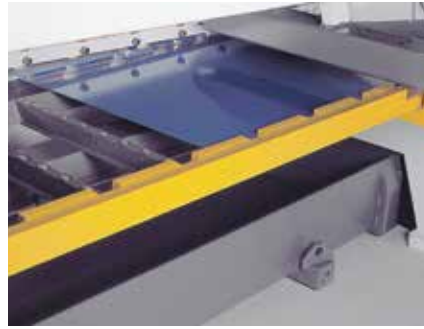
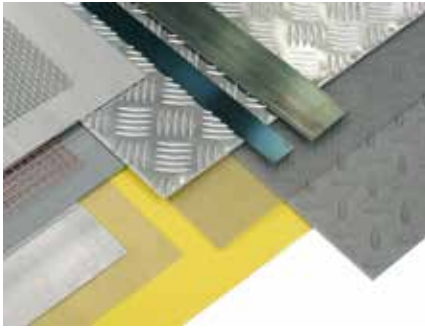

The sheet support system guides even thin materials exactly to the CNC backstop.

Front stops (available also with a precision scale) allow an accurate part positioning.



Small parts chute for sorting small blanks.



Spacious scrap container



Side free space for an easy blade change

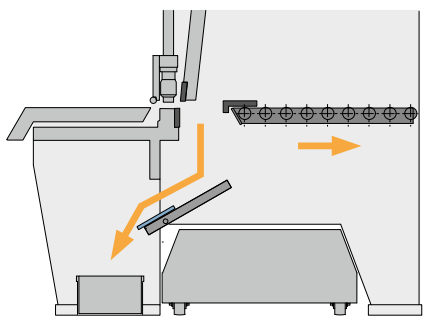

The programmable small parts chute delivers cut pieces (max. 200 x 500 mm) into a container in front of the machine.

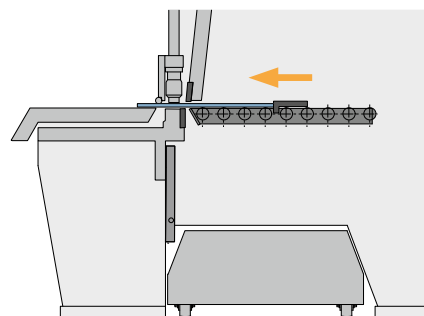

Return-back function: The CNC backstop can push a cut piece below the finger protection back to the operator. Less running around, more production time.

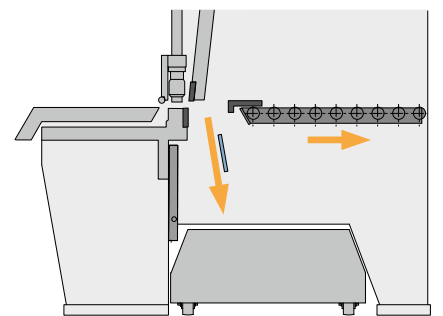

For trim cuts the sheet support moves backwards so that cut strips can fall into the spacious scrap container.

Technical data	Cutting length max.	Sheet thickness max.	Gauging depth
POWERcut RAS 86.43	4040 mm	5.0 mm	5 - 1000 (1500) mm
POWERcut RAS 86.33	3190 mm	6.3 mm	5 - 1000 (1500) mm

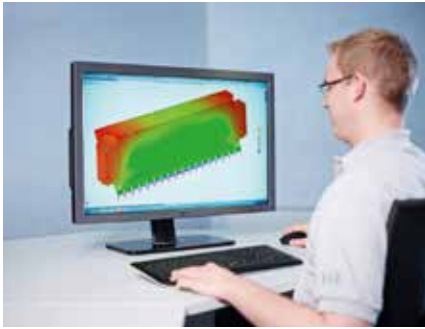

Design



Sawing



Plasma cutting



Milling



Turning



Grinding



Welding



Powder coating



Assembly



Electrical assembly



Quality inspection



RAS - Regional production for global sustainability



INNOVATION MADE IN GERMANY



09. 2018



Headquarters in Sindelfingen. In the foreground „Steel object“.



Efringen - factory and artwork



RAS Systems LLC in Georgia, USA

All sheet thickness refer to 400 N/mm² tensile strength. Subject to changes. Pictures may show options.



Founder Wilhelm Reinhardt



Managing Directors Rainer Stahl and Willy Stahl

RAS Reinhardt Maschinenbau GmbH

Richard-Wagner-Straße 4-10 | 71065 Sindelfingen

Fon: + 49-7031-863-0 | info@RAS-online.de

www.RAS-online.de